

## ON Semiconductor Device Nomenclature

Prepared by: Steve West  
ON Semiconductor



**ON Semiconductor®**

<http://onsemi.com>

---

### REFERENCE MANUAL

Whenever possible, ON Semiconductor uses the following numbering systems in the naming of their products.

The ESD/TVS, small signal diode and transistor, and thyristor portfolios have no single standard naming

#### Historical Nomenclature Notes

During its history, ON Semiconductor has been part of another company, and has acquired other companies and product lines. In order to maintain consistency for customers, part numbers have not changed, wherever possible. The following prefixes may indicate the original manufacturer:

- ADP** – Analog Devices, Inc.
- ADT** – Analog Devices, Inc.
- AMIS** – AMI Semiconductor
- ASM** – PulseCore
- CAT** – Catalyst Semiconductor
- CS** – Cherry Semiconductor
- MC** – Motorola

convention. They consist of many industry standard nomenclatures, along with several market targeted naming conventions. For any questions, please contact your local ON Semiconductor sales representative.

#### Current Nomenclature Notes

Analog .....	2
CMOS Logic .....	3
Analog Switch .....	3
Clock and Data Management .....	4
Integrated Solutions .....	6
MOS Power .....	7
Power MOSFETs – SO-8 (MiniMOS™), Micro8™, SOT-223, and TSOP-6 .....	8
Bipolar Power .....	9
Rectifiers .....	11
FMO Bump .....	12
Ambient Light Sensors .....	12
Contact Image Sensors & Modules .....	13
Photo Diode Arrays .....	14
LED/Lighting Products .....	14

# TND310

## Naming Convention for Analog Devices

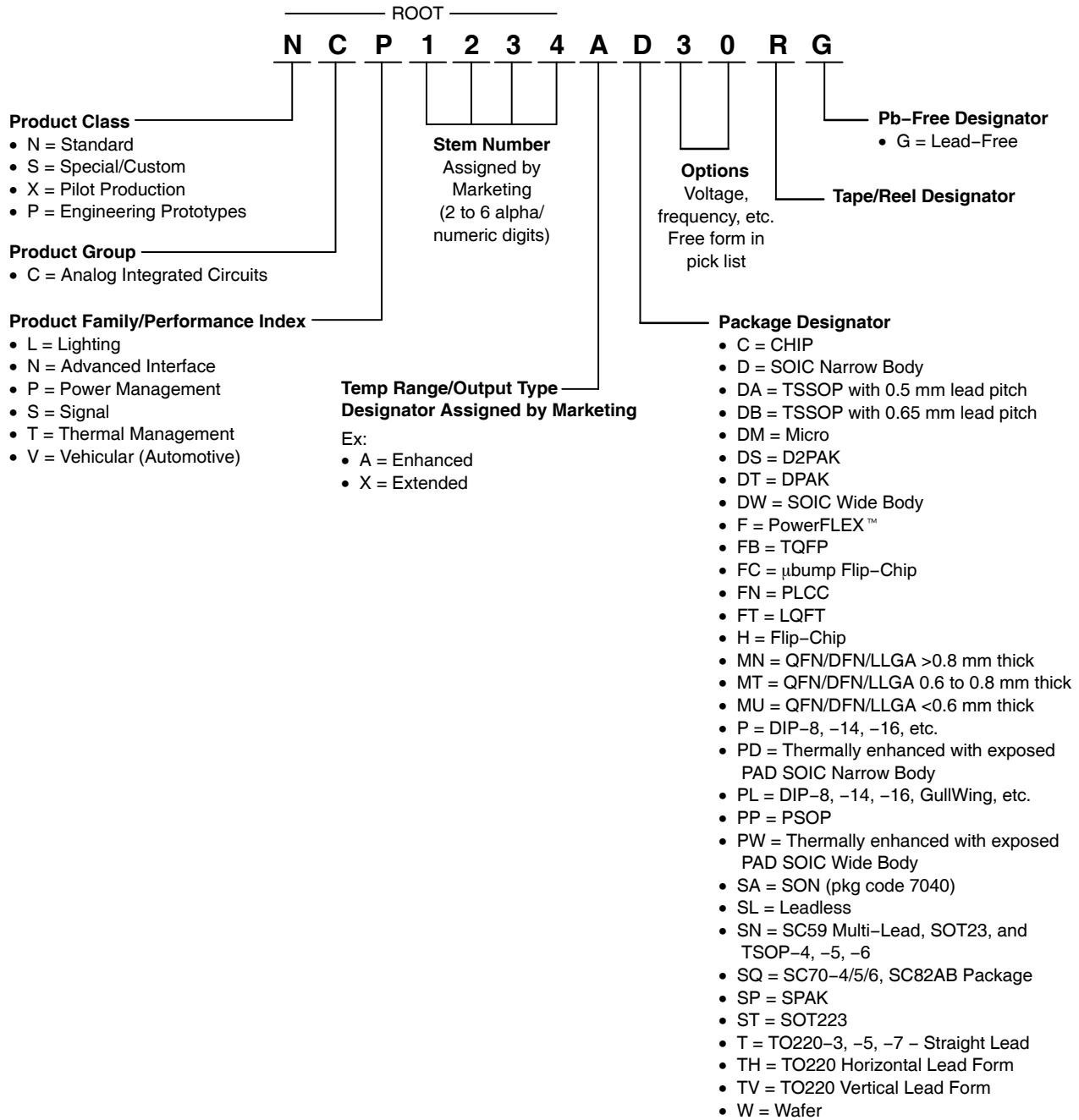

# TND310

## Naming Convention for CMOS Logic Family Devices

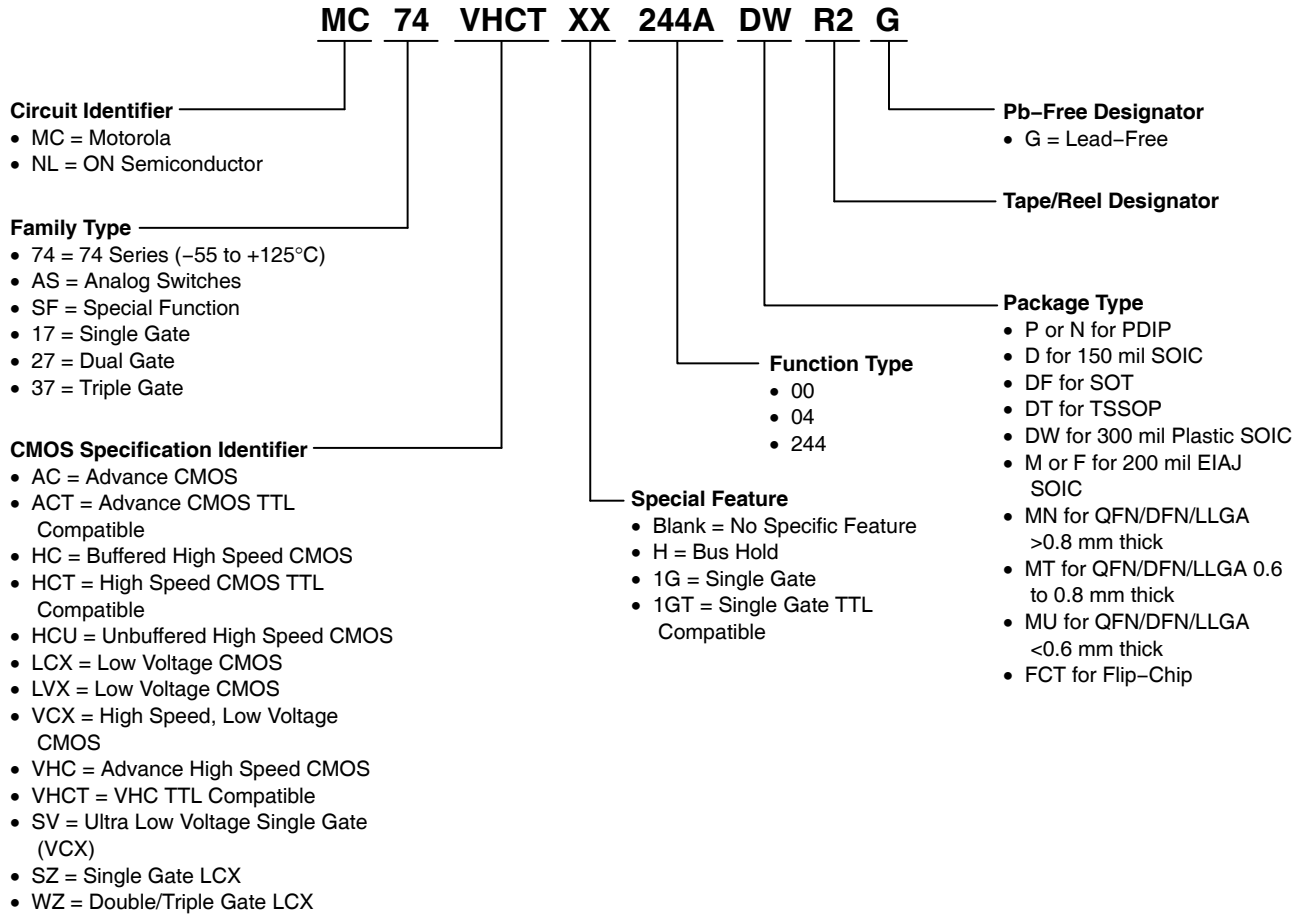

## Naming Convention for Analog Switch Devices

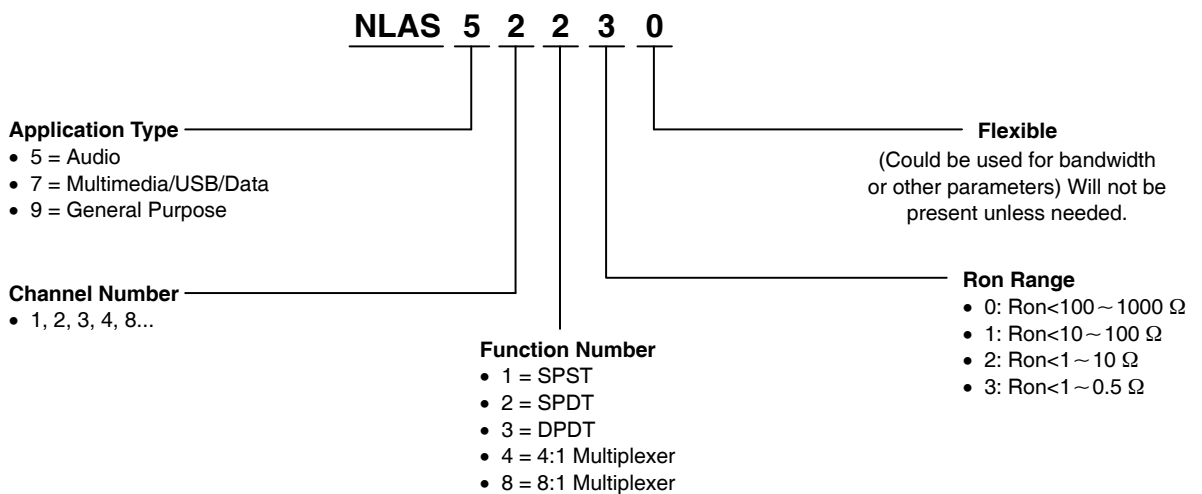

# TND310

## Naming Convention for Clock and Data Management Devices

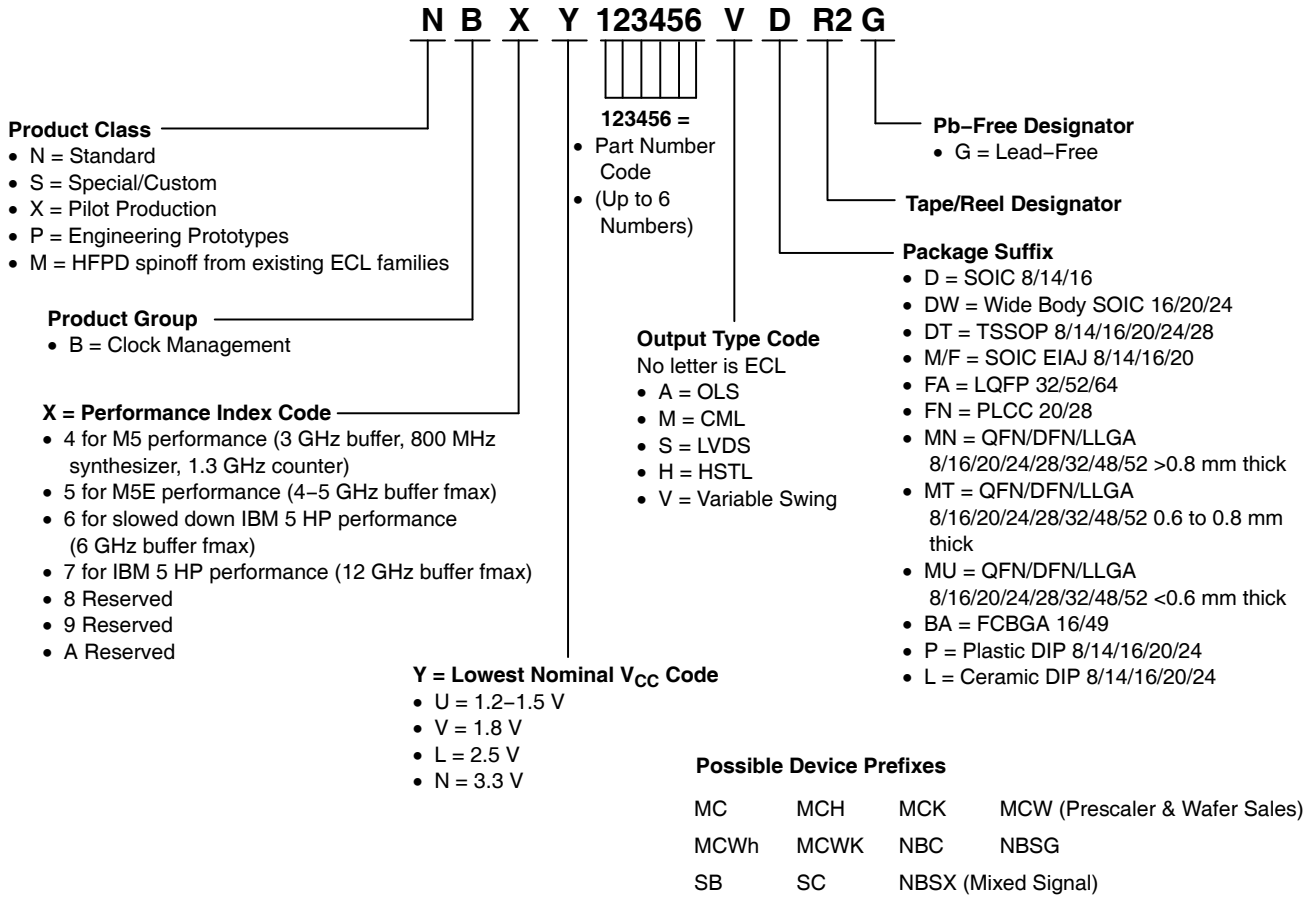

# TND310

## Naming Convention for Crystal Oscillator Devices

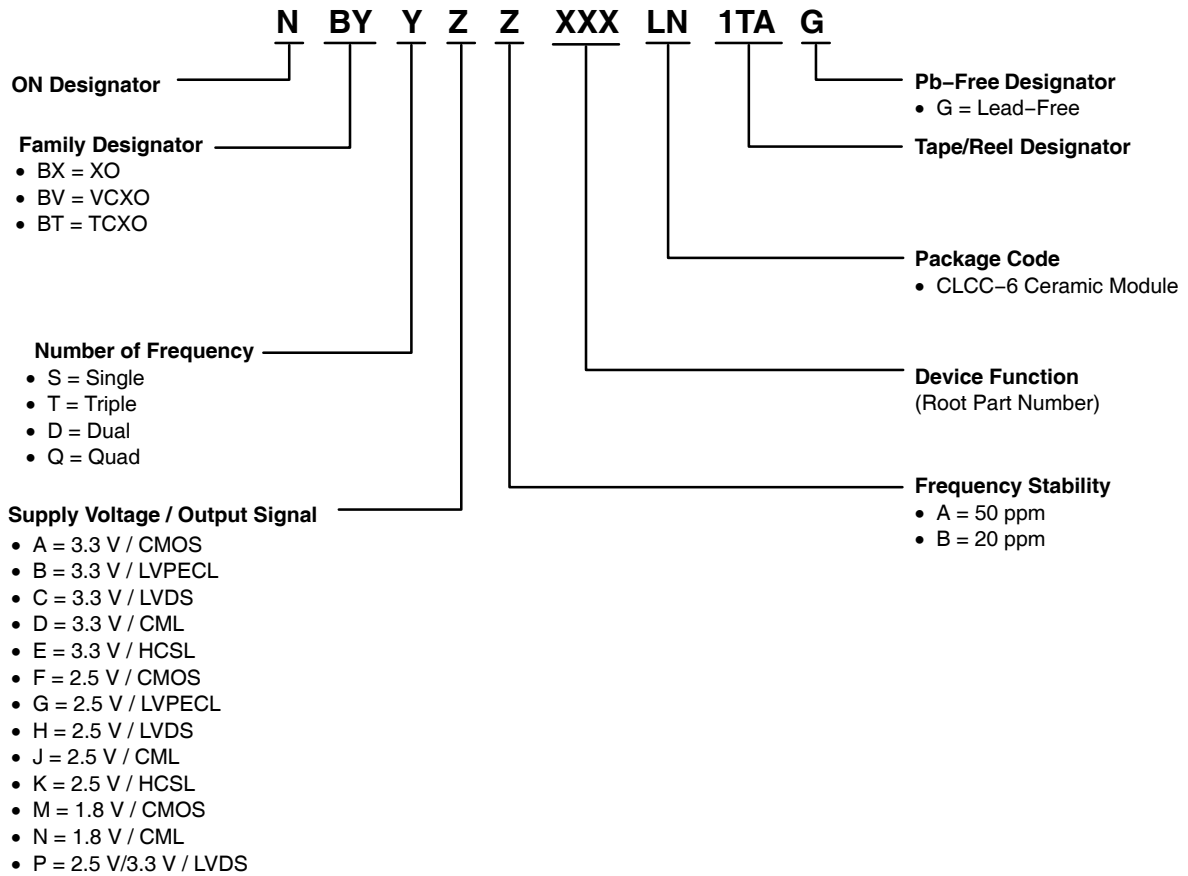

# TND310

## Naming Convention for Integrated Solutions Devices

**N U D 3 1 3 4 X 6 T 1 G**

### Product Class

- N = Standard
- S = Special/Custom
- X = Pilot Production
- P = Engineering Prototypes

### Product Group

- U = MicroIntegration™
- I = Smart

### Product Family

- D = Driver
- F = Filter
- P = Protection
- S = Special Function

### Descriptor 1

Product Family Description	Symbol
Drivers Legacy	3
LED	4
Filters # of Filters	1-9
Protection # of Protected Lines	1-9
SpecFunct/Customer Special Part No	0-9

### Descriptor 2

Product Family Description	Symbol
Driver Function Type	1
Filter Part Number	0-9
Protection Line Type	1
Protection Line Type	2
SpecFunct/Customer Special Part No	0-9

### Symbol Definition

Symbol	Symbol Definition
1	Relay
0-9	4 = Audio Filters
1	Data Line Only
2	Data and Power Line
0-9	

### Pb-Free Designator

- G = Lead-Free

### Tape/Reel Designator

### Package Designator

- V = 24 Pin MLF
- H = ChipFET™
- B = D2PAK
- C = DPAK
- - Die T & R
- FC = Flip-Chip
- K = Micro8™
- U = MicroLeadless™
- QP = PLLP
- SN = POWERMITE®
- MN = QFN/DFN: >0.8 mm thick
- MT = QFN/DFN: 0.6 to 0.8 mm thick
- MU = QFN/DFN: <0.6 mm thick
- P5 = SOT953
- P6 = SOT963
- WT = SC70
- T = SC75/SC89
- W1 = SC88
- W5 = SC88A
- A = SMA
- S = SMC
- D = SOIC
- Z = SOT223
- L = SOT23
- XV5 = SOT553
- XV6 = SOT563
- E = SPAK
- M5 = TSOP5
- M = TSOP6/SC74

'D' before pkg designator indicates dual.  
 '1' after pkg designator = latch off SMAR only.  
 '2' after pkg designator = auto-retry for S products only.

### Descriptor 3, 4

Product Family Description	Symbol
Driver Part Number	0-9
Filter Part Number	0-9
Protection Part Number	0-9
SpecFunct/Customer Special	0-9

# TND310

## Naming Convention for MOS Power Devices

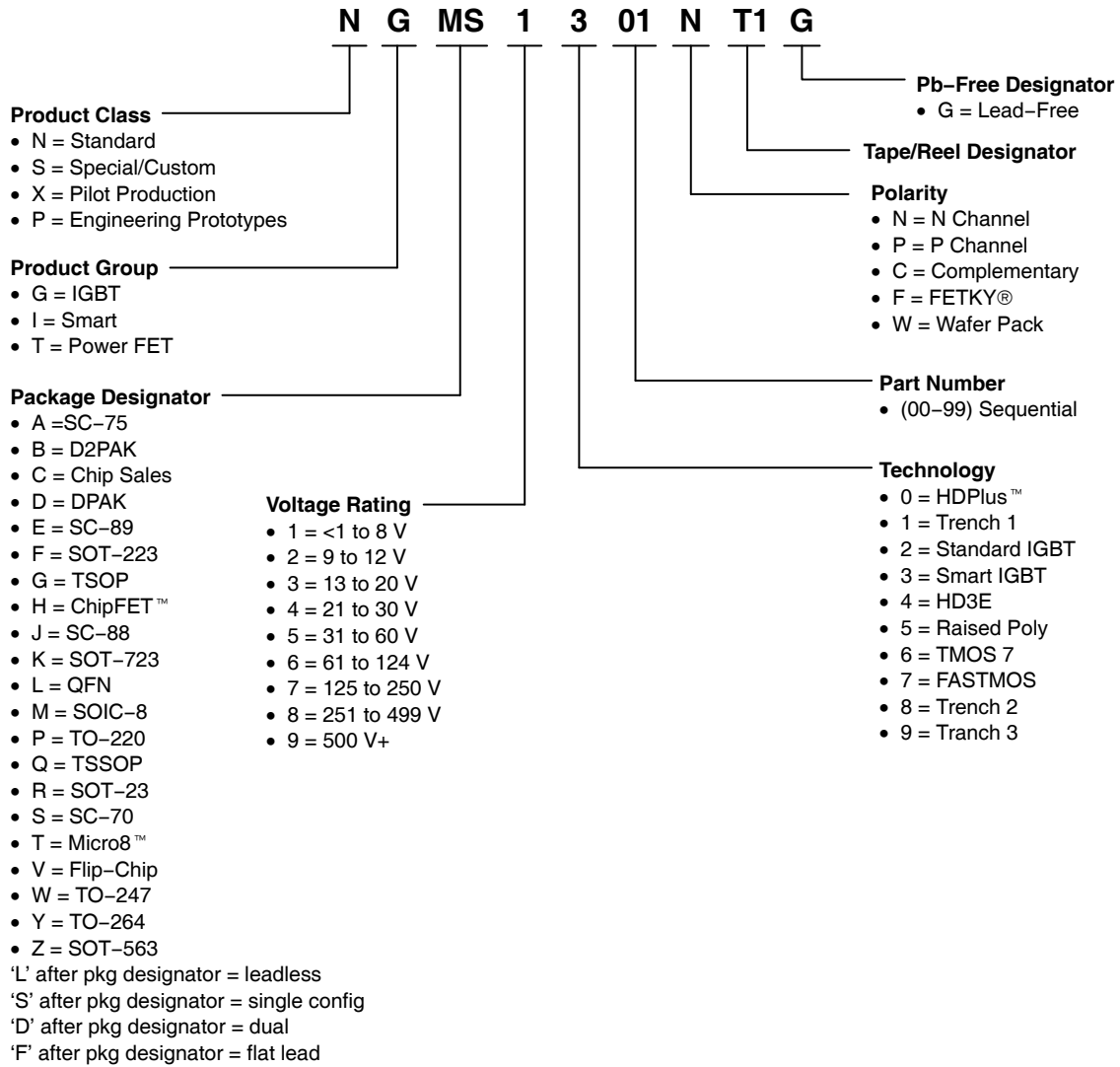

# TND310

## Naming Convention for SO-8 (MiniMOS™), Micro8™, SOT-223, and TSOP-6 Power MOSFETs

### PREVIOUS FORMAT 1

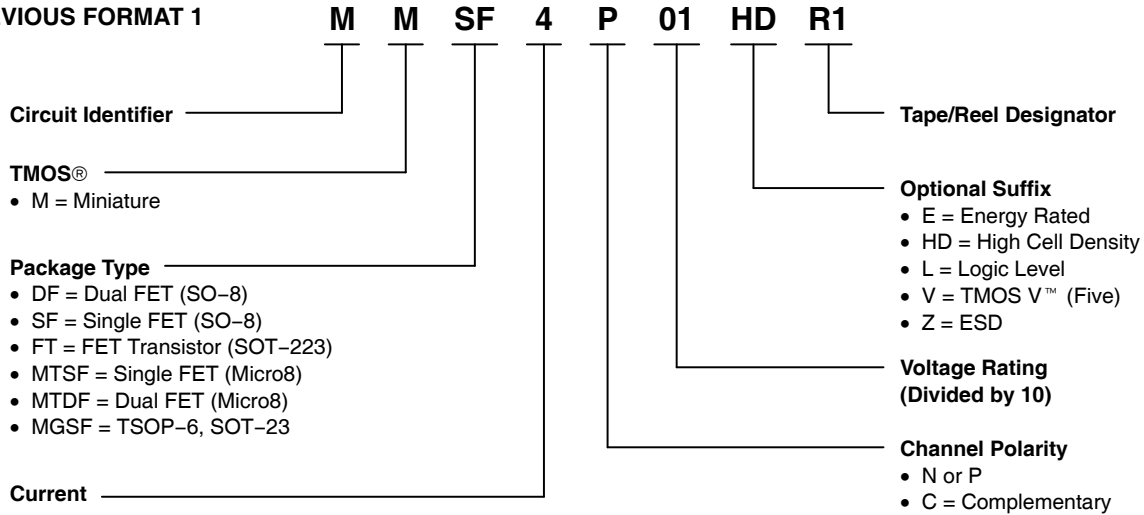

### PREVIOUS FORMAT 2

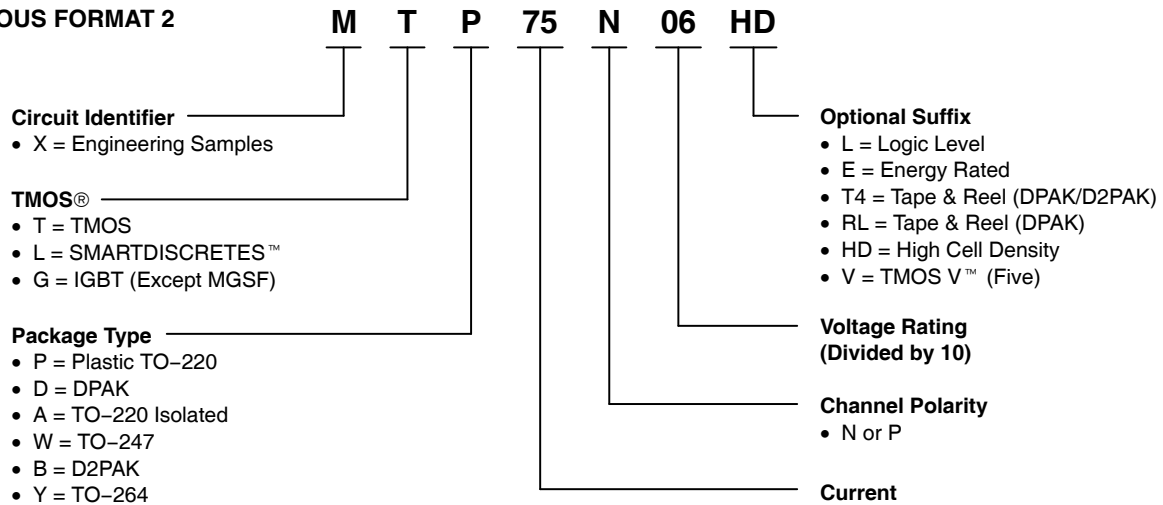

### PREVIOUS FORMAT 3

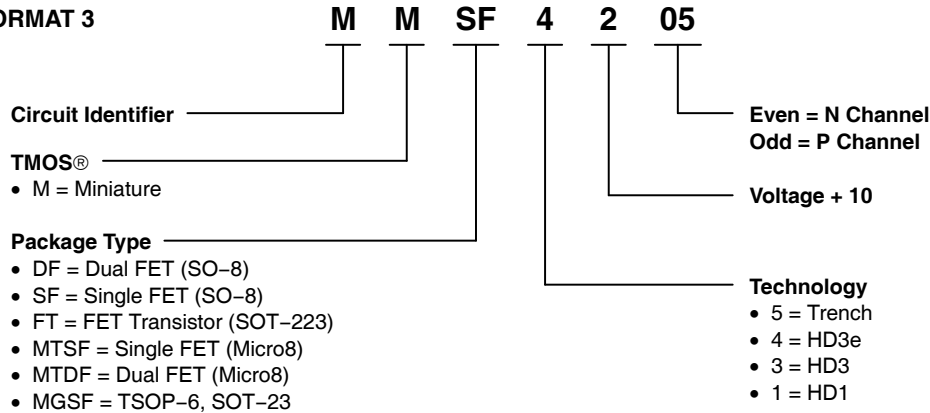



# TND310

## Naming Convention for Bipolar Power Devices

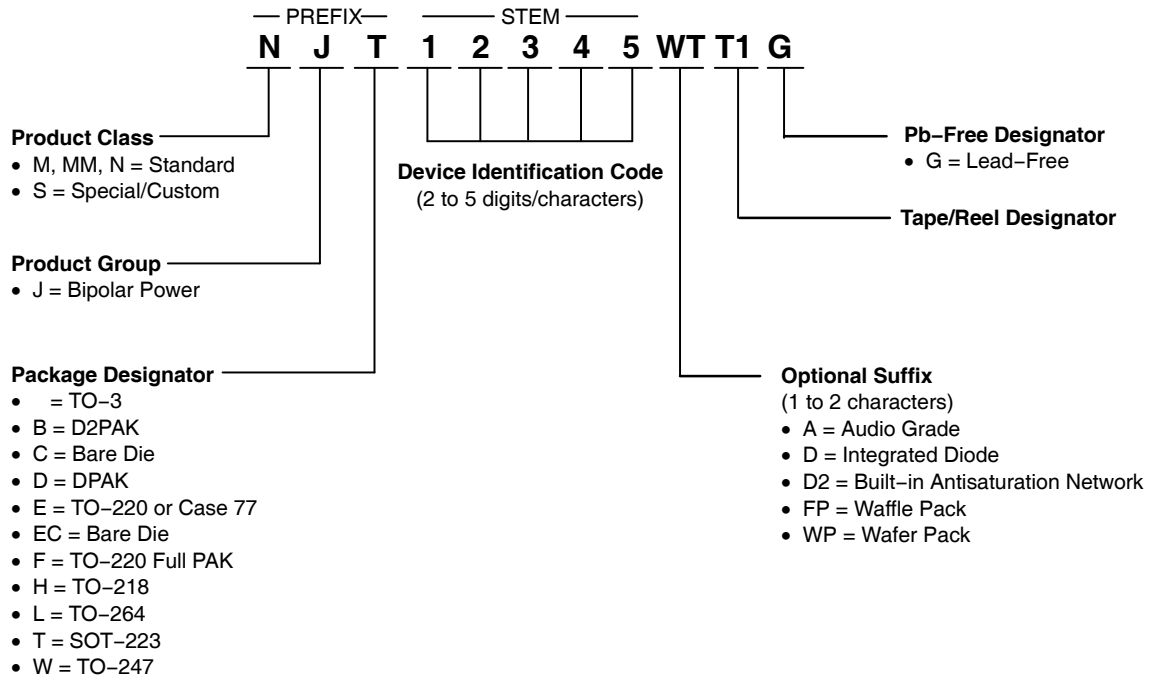

# TND310

## Naming Convention for Bipolar Power

### PREVIOUS FORMAT 1

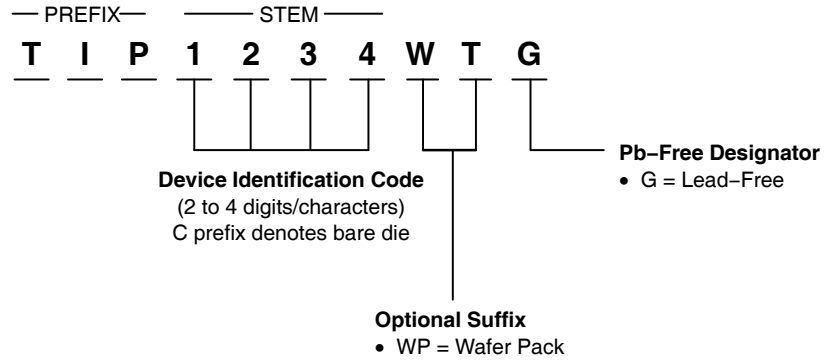

### PREVIOUS FORMAT 2

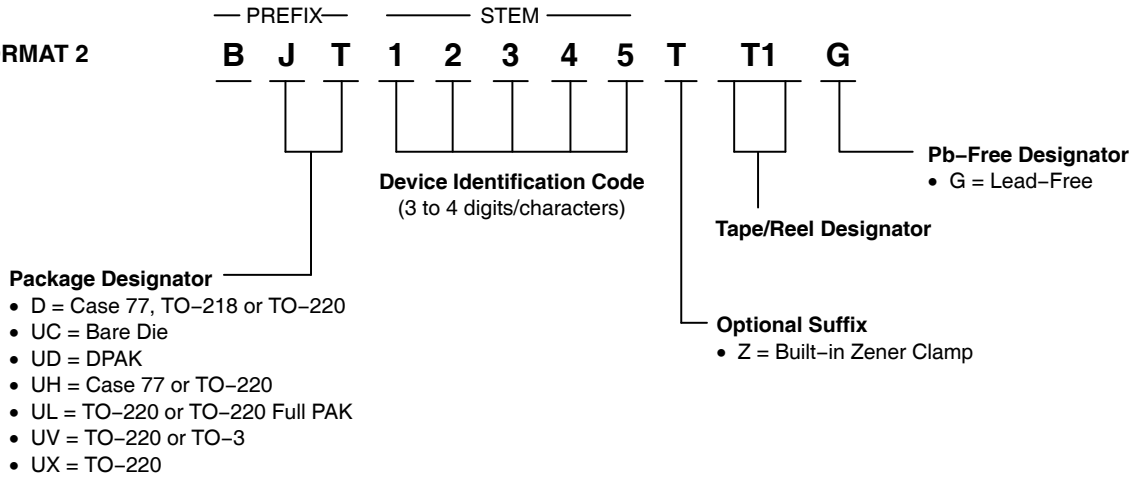

### PREVIOUS FORMAT 3

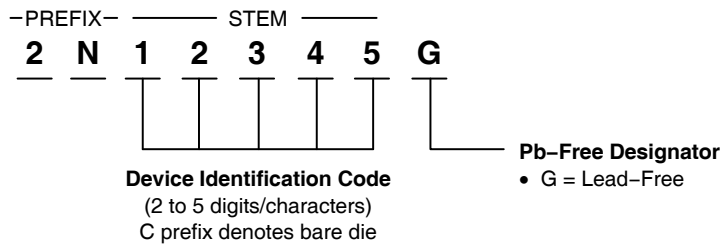

# Naming Convention for Rectifier Devices

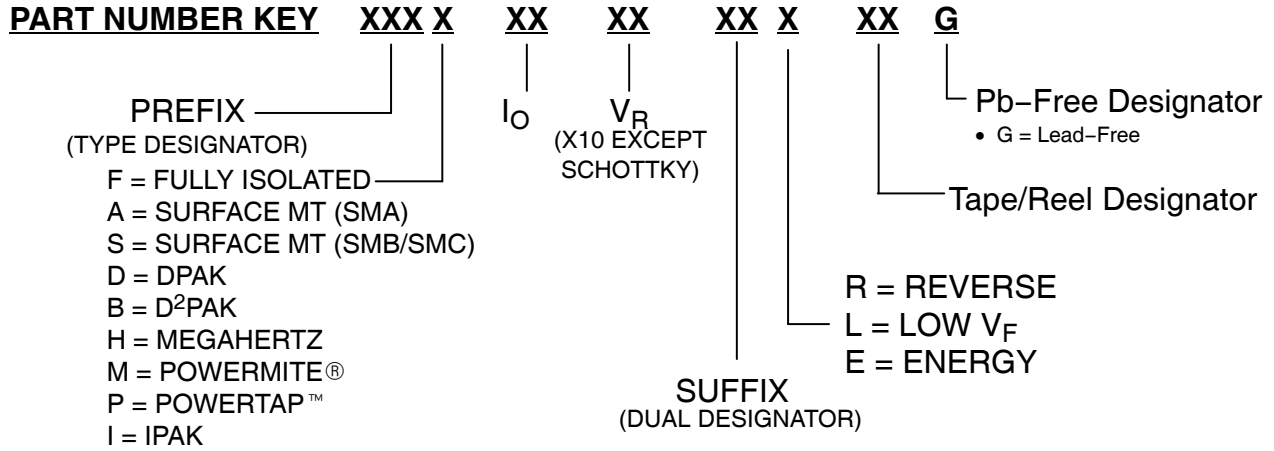

**PREFIX KEY**

MUR = ULTRA FAST RECTIFIER  
 MBR = (SCHOTTKY) BARRIER RECTIFIER  
 MR = STANDARD & FAST RECOVERY  
 MSR = ULTRASOFT

**SUFFIX KEY**

CT = CENTER TAP (DUAL) TO-220, POWERTAP, DPAK, D<sup>2</sup>PAK  
 PT = CENTER TAP (DUAL) TO-218 PACKAGE  
 WT = CENTER TAP (DUAL) TO-247  
 SF = SOD-123 FLAT LEAD  
 PF = POWER FACTOR CORRECTION SPECIFIC

**EXAMPLE:**

MUR	30	20	WT
ULTRAFAST	30 AMP	200 V	CENTER TAP (DUAL) TO-247

**EXAMPLE:**

MBR	30	45	WT
SCHOTTKY	30 AMP	45 V	CENTER TAP (DUAL) TO-247

# TND310

## Naming Convention for FMO Bump

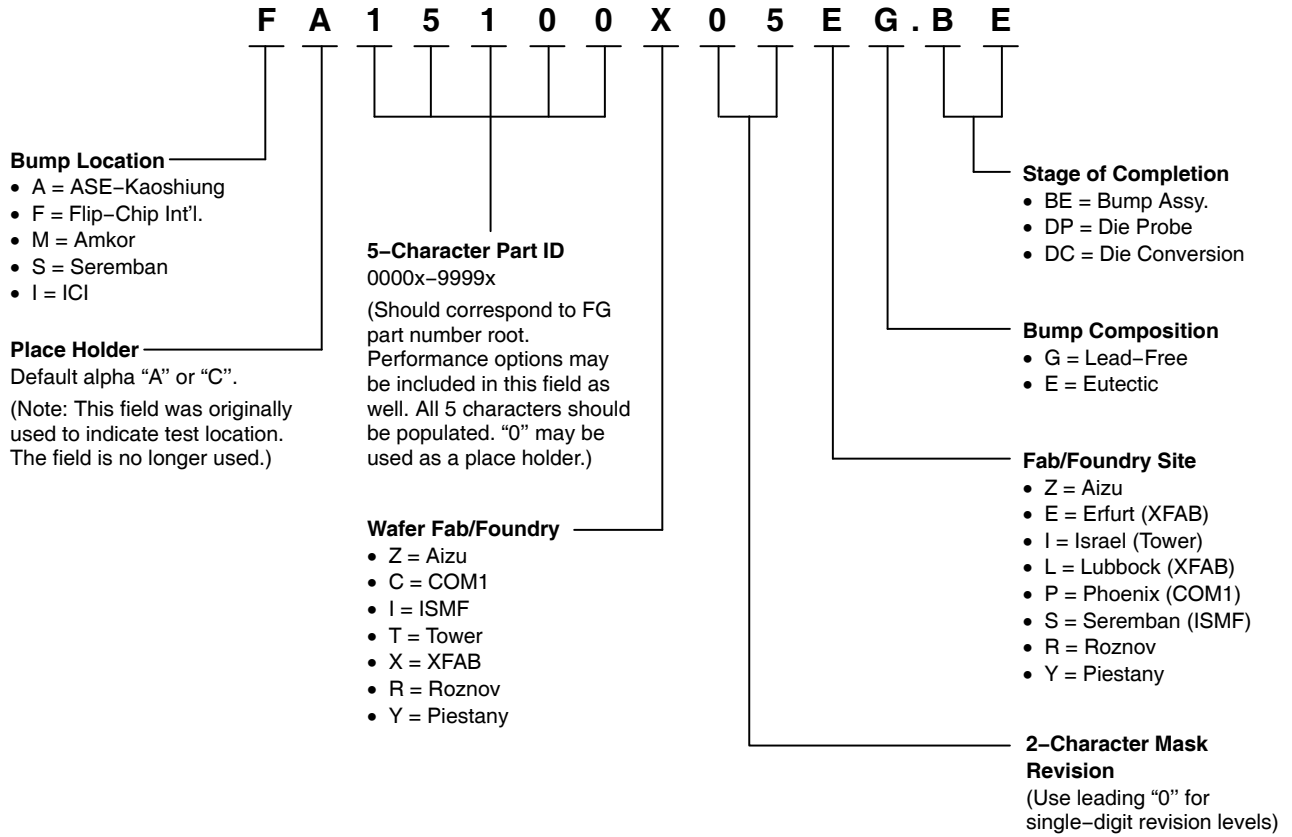

## Naming Convention for Ambient Light Sensor Devices

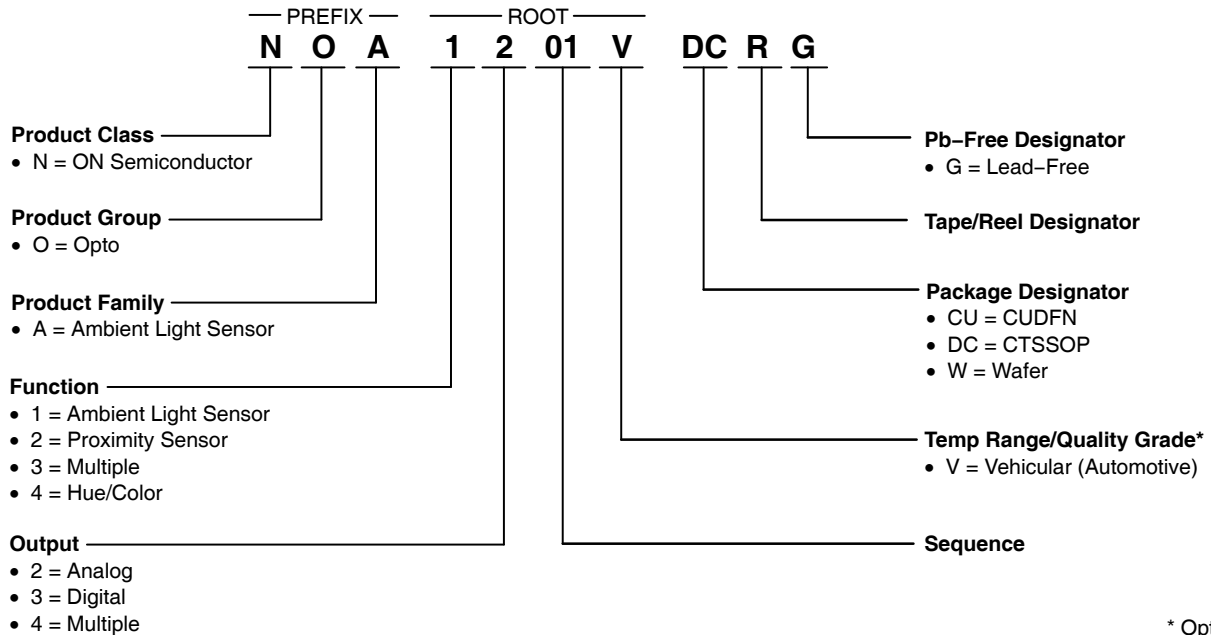

\* Optional

# TND310

## Naming Convention for Contact Image Sensor Devices

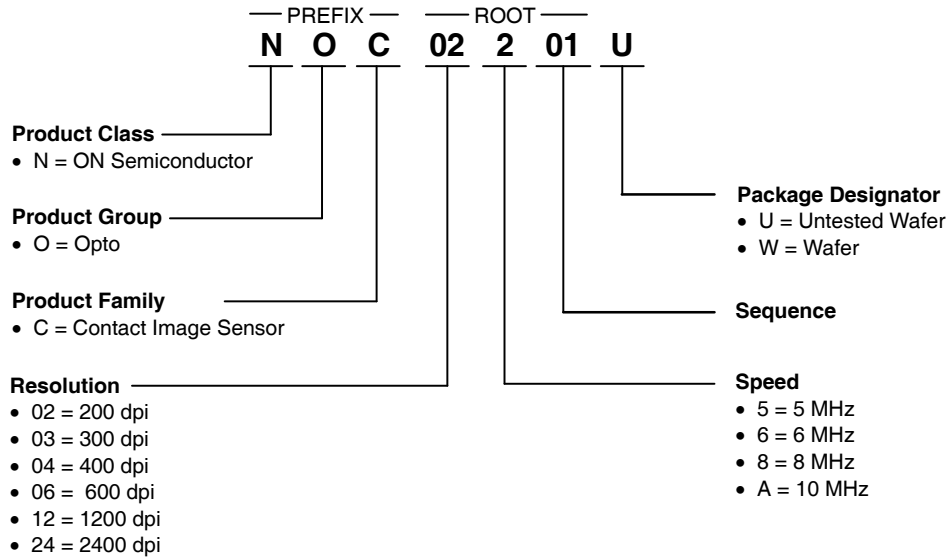

## Naming Convention for Contact Image Sensor Modules

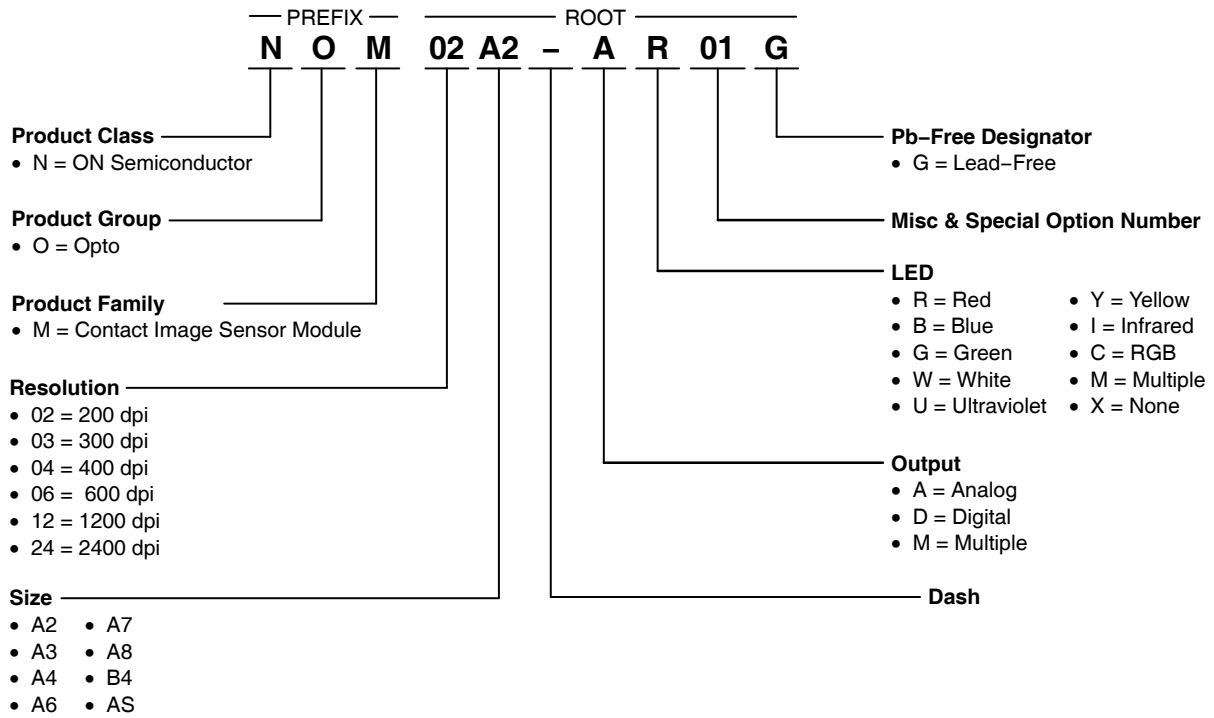

**Naming Convention for Photo Diode Array Devices**

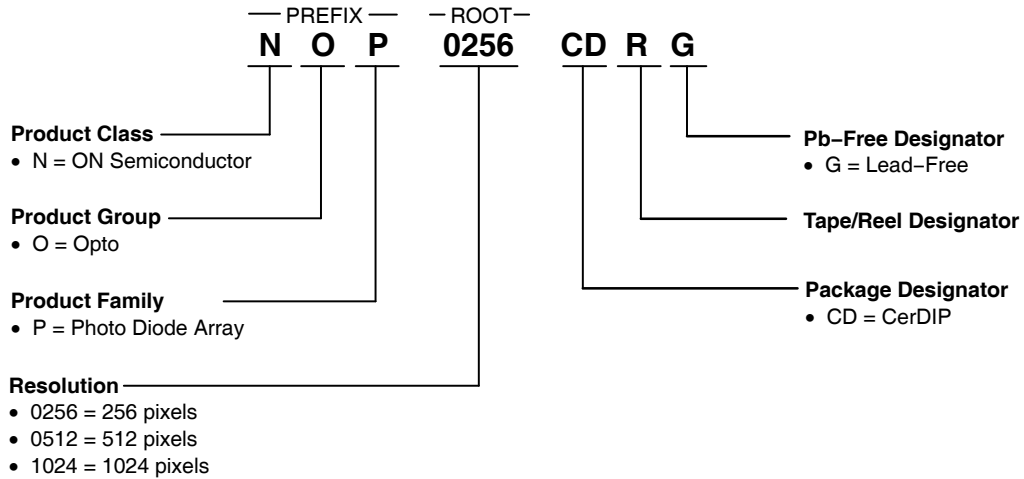

**Naming Convention for LED/Lighting Products**

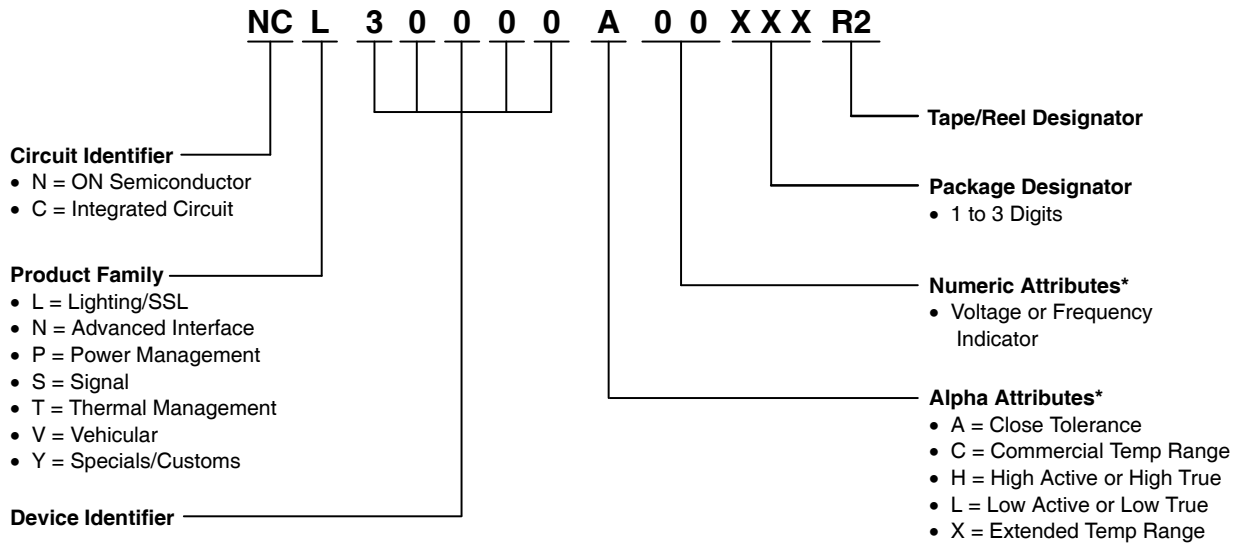

\* Optional

HDPlus, MicroIntegration, MicroLeadless, MiniMOS, POWERMAP, SMARTDISCRETES, and SMART HotPlug are trademarks of Semiconductor Components Industries, LLC (SCILLC).

ChipFET is a trademark of Vishay Siliconix.

FETKY is a registered trademark of International Rectifier Corporation.

Micro8 is a trademark of International Rectifier.

PowerFLEX is a trademark of Texas Instruments Incorporated.

POWERMITE is a registered trademark of and used under a license from Microsemi Corporation.

TMOS V is a trademark of Motorola, Inc.

**ON Semiconductor** and  are registered trademarks of Semiconductor Components Industries, LLC (SCILLC). SCILLC reserves the right to make changes without further notice to any products herein. SCILLC makes no warranty, representation or guarantee regarding the suitability of its products for any particular purpose, nor does SCILLC assume any liability arising out of the application or use of any product or circuit, and specifically disclaims any and all liability, including without limitation special, consequential or incidental damages. "Typical" parameters which may be provided in SCILLC data sheets and/or specifications can and do vary in different applications and actual performance may vary over time. All operating parameters, including "Typicals" must be validated for each customer application by customer's technical experts. SCILLC does not convey any license under its patent rights nor the rights of others. SCILLC products are not designed, intended, or authorized for use as components in systems intended for surgical implant into the body, or other applications intended to support or sustain life, or for any other application in which the failure of the SCILLC product could create a situation where personal injury or death may occur. Should Buyer purchase or use SCILLC products for any such unintended or unauthorized application, Buyer shall indemnify and hold SCILLC and its officers, employees, subsidiaries, affiliates, and distributors harmless against all claims, costs, damages, and expenses, and reasonable attorney fees arising out of, directly or indirectly, any claim of personal injury or death associated with such unintended or unauthorized use, even if such claim alleges that SCILLC was negligent regarding the design or manufacture of the part. SCILLC is an Equal Opportunity/Affirmative Action Employer. This literature is subject to all applicable copyright laws and is not for resale in any manner.

## PUBLICATION ORDERING INFORMATION

### LITERATURE FULFILLMENT:

Literature Distribution Center for ON Semiconductor  
P.O. Box 61312, Phoenix, Arizona 85082-1312 USA  
**Phone:** 480-829-7710 or 800-344-3860 Toll Free USA/Canada  
**Fax:** 480-829-7709 or 800-344-3867 Toll Free USA/Canada  
**Email:** [orderlit@onsemi.com](mailto:orderlit@onsemi.com)

**N. American Technical Support:** 800-282-9855 Toll Free  
USA/Canada

**Japan:** ON Semiconductor, Japan Customer Focus Center  
2-9-1 Kamimeguro, Meguro-ku, Tokyo, Japan 153-0051  
**Phone:** 81-3-5773-3850

**ON Semiconductor Website:** <http://onsemi.com>

**Order Literature:** <http://www.onsemi.com/litorder>

For additional information, please contact your local Sales Representative.